



Atop Technologies, Inc.

IEC61850-3 IEEE1588v2 24G+4 10G-port High Availability Modular Managed Rackmount Gigabit Switch

RHG9528 / RHG9628 Series

Hardware Installation Guide

Version 1.2
Updated in July, 2021



Tel: 886-3-5508137
Fax: 886-3-5508131
www.atop.com.tw

P/N:89900599G

Package Check List

Inside the package you will find the following items:

- Industrial Managed Rack-Mount Modular Gigabit Ethernet Switch x 1
- Rack Mount Kit x 2
- 2-pin Terminal block x 1 for the relay output
- Protective caps for all SFP ports (Depend on purchased model)
- Installation Guide with Warranty Card x 1

Never install or work on electrical or cabling during periods of lightning activity. Never connect or disconnect power when hazardous gases are present.

Warning: Hot Surface Do Not Touch.

Caution: CLASS 1 LASER PRODUCT. Do not stare into the laser!

This equipment should be installed indoor and not connect directly with equipment installed outdoor.

Throw the device must follow RoHS procedure to recycle

Product Layout

AC / DC / HVDC + M1~M6 Front View

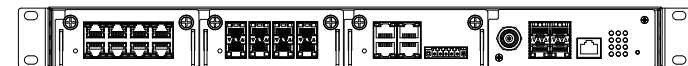

AC + AC Back View

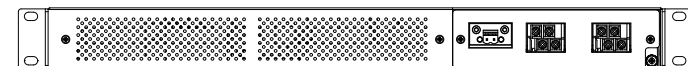

DC + AC

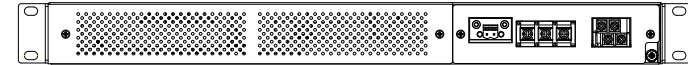

DC + HVDC / DC + DC / HVDC + HVDC

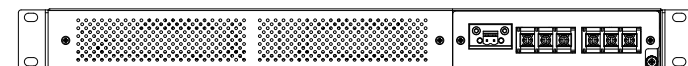

Installation Overview

The device's appearance is as in the figure below.

- Ground the device properly. You can use the FG pin in the terminal block. It is required to connect to the grounds at all times to ensure overall maximum performance.
- If you opt to place the device on a rack, you will need to secure the rack mounts kit on to the device before placing it on the rack. If you opt to place the device on a surface, you can put on the foot rubbers to prevent the device from sliding.
- You can then choose whether to plug in the I/O ports at this point or do it later. Next you can then proceed to connect the device to the LAN (switch or PC), take care on using the RJ-45 connector; after this we can then proceed to the device's settings.
- The openings to the sides are for the devices heat dissipation. Please never obstruct or cover them with any objects.
- This switch's factory IP by default is 10.0.50.1 . you can access the device by its Web UI once it is connected to a physical network (or using Management Utility, for more information on Management Utility, please refer to its manual). Please be aware that the PC needed for this procedure needs to be in the same subnet, or you may refer yourself to the device User's Manual.

Pin Assignments and Connections

10/100/1000BASE-T(X) Ethernet, and RS-232 Console Pinouts

RJ-45								
10/100BASE-T(X)								
Pin	1	2	3	4	5	6	7	8
Signal	Tx+	Tx-	Rx+			Rx-		
1000BASE-T								
Pin	1	2	3	4	5	6	7	8
Signal	BI_DA+	BI_DA-	BI_DB+	BI_DC+	BI_DC-	BI_DB-	BI_DD+	BI_DB-
10G SFP+								
PPS output	 50 ohm TTL out * RG58/RG174 Coaxial Cable							
RS232 Console								
RS-232 Console								
Pin	1	2	3	4	5	6	7	8
Signal			Tx	GND	GND	Rx		

1000BASE-X Fiber Optics SFP Slot

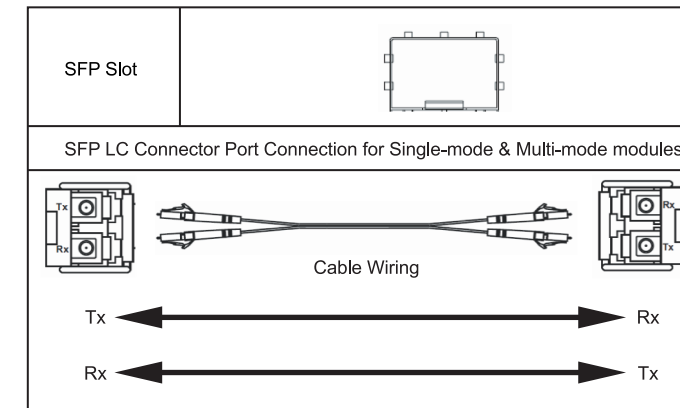

Caution
The SFP slot should be used in conjunction with a MSA compliant optical transceiver.

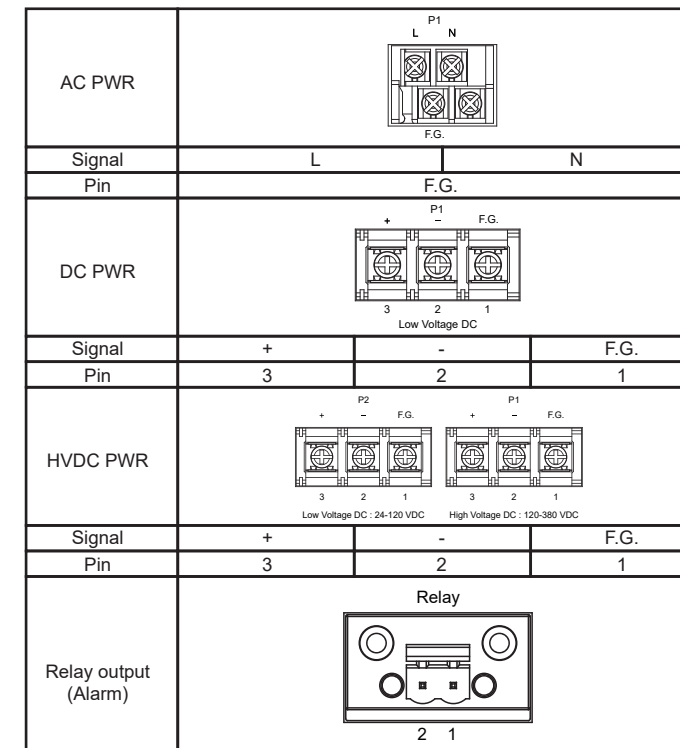

Power Requirements

- Power input : 110-240 VAC, 0.7A Max, 50/60Hz (For AC version models)
24-120 VDC, 2.66A Max, 64W Max (For DC version models)
120-380 VDC, 0.52A Max, 62W Max (For HVDC version models)
- Alarm output : 1A@24A VDC for signal use only

LED Indicators

P1/P2	Green	On	Power is supplied from PWR1/PWR2
		Off	No power input detected from PWR1/PWR2
ALM	Red	On	Alarm is triggered by user defined events
		Off	Alarm is not triggered by user defined events
RUN	Green	Blinking	AP firmware is running normally
		Off	System is not ready or halt
Ring	Green	On	All rings in normal condition or Cchain in normal condition
		Blinking	Ring in protection state or a port is link-down in Cchain
R.M.	Green	On	The device is a Master of the ERPS Ring or Ia-Ring or a Head of Cchain
		Blinking	The device is a Tail of Cchain
LAN	Amber	On	Ethernet is linked at 1000Mbps
		Blinking	Ethernet is linked at 100Mbps
SFP (1G)	Green	On	Ethernet is linked
		Blinking	Ethernet is active and data is being transmitted
SFP (10G)	Amber	On	Ethernet is linked at 1000Mbps
		Blinking	Ethernet is linked at 100Mbps
Time-S	Green	On	Ethernet is active and data is being transmitted
		Off	Ethernet is not linked
PPS	Green	On every second	Ethernet is active and data is being transmitted
		Off	Ethernet is not linked
SYNC	Green	On	M3/M4 Time Code Output Enable.
		Off	Time formal Disable.
HOLD	Green	On	At the same time of the PPS pulse send out from BNC port
		Off	No PPS pulse sent out
S7/S8	Green	On	SyncE on Locked mode
		Off	SyncE Disable and system on free run mode
S7/S8	Green	Blinking	SyncE on Lock acquisition
		On	Entry Holdover active mode.
S7/S8	Green	On	Holdover History mode valid
		Off	Holdover History mode invalid
S7/S8	Green		Reserved by application

Field Maintenance and Service

If the device requires servicing of any kind, you may need to disconnect and remove it from its mounting. The initial installation should be done in a way that makes this as convenient as possible.

- Voltage/Power lines should be properly insulated as well as other cables. Be careful when handling the so as to not trip over
- Do not under any circumstance insert foreign objects of any kind into the heat dissipation holes located in the different faces of the device. This may not only harm the internal layout but might cause harm to you as well.
- Do not under any circumstance open the device for any reason. Please contact your dealer for any repair needed or follow the instructions on section of your User's Manual.

Attention

1. It is recommend to use at least a 14 AWG cable for the AC power input. It is suggested the cable to be resistant to at least 90°C temperature on the power connector.
2. If the equipment is used in a manner not specified by the manufacturer, the protection provided by the equipment may not be impaired.
3. Clean the device with dry or humid (water) soft cloth.
4. Before powering on the device, the Functional Ground (Grounding Screw) shall be connected to the ground.
5. Place the power cord where it can be easily disconnected
6. The device can only be accessed by skilled person
7. Equipment is intended for installation in Restricted Access Area.
8. Connect earthed cable which is of AWG 14 min. Green-and-yellow wire from earth of building to the protective bonding earthed terminal of the equipment.
9. CAUTION, SHOCK HAZARD, TO DISCONNECT POWER , REMOVE ALL POWER CORDS FROM UNITS.
10. Power installation must be performed with qualified electrician and followed with National Electrical Code, ANSI/NFPA 70 and Canadian Electrical Code, Part I, CSA C22.1.

Environmental Limits

- Operating Tem perature: -40 to 85°C (-40 to 185°F)
- Operating Temperature(For UL): -40 to 75°C (-40 to 167°F)
- Storage Temperature: -40 to 85°C (-40 to 185°F)
- Ambient Relative Humidity: 5 to 95%, 55°C (non-condensing)
- Altitude: up to 2,000 m
- Housing Protection : IP 30

Mechanical Dimensions (Unit=mm)

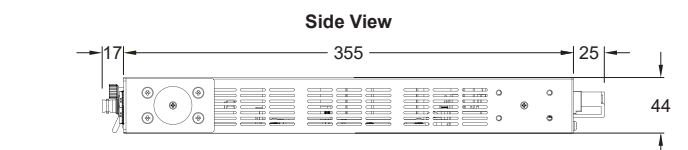
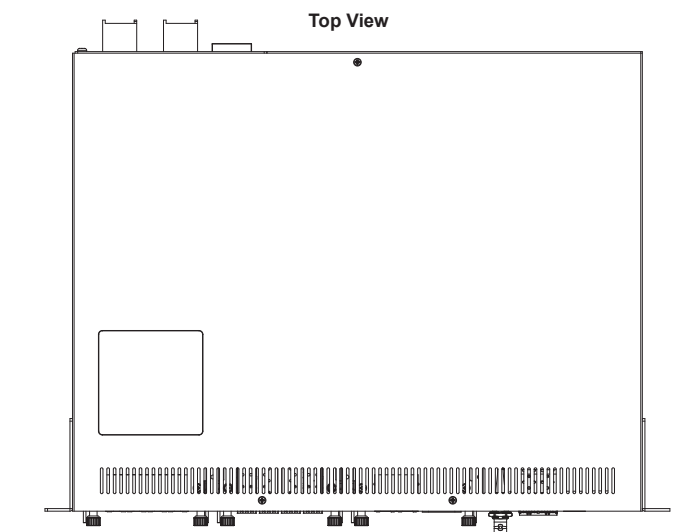
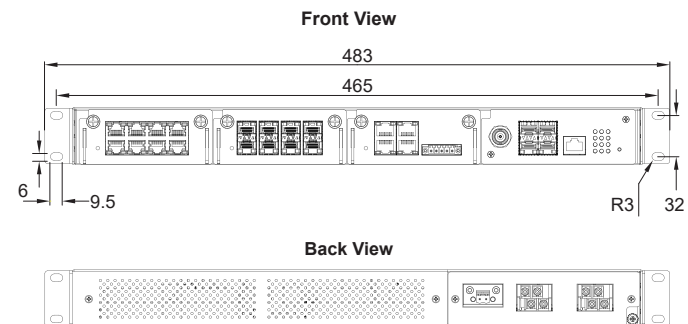

Installation manual of field wiring for Gigabit Switch Power connected

This equipment must be installed and removed by trained skilled person in a restricted-access location, as defined by the NEC and IEC 62368-1, The Standard for Safety of Audio/video, information and communication technology equipment. Safety statement

1. CAUTION:



To reduce the risk of electric shock or energy hazards:

It is the customer's responsibility to supply the necessary power cable.

- ① Use a circuit breaker that is rated at 20 amps.
 - ② Use 1.5 mm² (14 AWG) single copper wire, or 1.5 mm² (14 AWG) Multi-core copper at 90° C
 - ③ Stripping the wire, leave the bare lead approximately 10mm for terminals connection.
 - ④ Torque the wiring-terminal screws to 0.50 ~ 0.60 newton-meters (4.43 ~ 7 inch-pounds)
2. If the power source requires ring terminals, you must use a crimping tool to install the ring terminals to the power cord wires. The ring terminals must be UL approved and must accommodate the wire that is described in above.

3. This equipment is designed to permit the connection of the earthed conductor of the power supply circuit to the earthed conductor at the equipment.

This equipment is designed to permit the connection of the earthed conductor of the power supply circuit to the earthed conductor at the equipment. If this connection is made, all of the following conditions must be met:

- ① This equipment shall be connected directly to the power supply system earthed electrode conductor or to a bonding jumper from an earthing terminal bar or bus to which the power supply system earthed electrode conductor is connected.
- ② This equipment shall be located in the same immediate area (such as, adjacent cabinets) as any other equipment that has a connection between the earthed conductor of the same dc supply circuit and the earthed conductor, and also the point of earthed of the power system. The power system shall not be earthed elsewhere.
- ③ The power supply source shall be located within the same premises as this equipment.
- ④ Switching or disconnecting devices shall not be in the earthed circuit conductor between the dc source and the point of connection of the earthed electrode conductor.

To Connected Power to Gigabit Switch

1. Turn OFF all power sources and equipment that is to be attached to this product.
2. Attach signal cables to the product.
3. Attach power cords to the product.

- ① For dc systems, ensure correct polarity of 24-120V or 120-380V dc connections, Earth ground should use a two-hole lug for safety.
- ② For AC systems, ensure correct polarity of connections, Earth ground should use a two-hole lug for safety
4. Attach signal cables to other devices.
5. Connect power cords to their sources.
6. Turn ON all the power sources.

To Disconnected Power to Gigabit Switch:

1. Turn OFF all power sources and equipment that is to be attached to this product.
- ① Disconnect dc power sources at the breaker panel or by turning off the power source. Then, remove the power cables.
2. Remove the signal cables from the connectors.
3. Remove all cables from the devices.

Caution, Shock hazard

Disconnect all power sources



Electrical current from power, telephone, and communication cables is hazardous.

To avoid a shock hazard:

- ① Do not connect or disconnect any cables or perform installation, maintenance, or reconfiguration of this product during an electrical storm.
- ② Connect to properly wired power sources any equipment that will be attached to this product.
- ③ When possible, use one hand only to connect or disconnect signal cables.
- ④ Never turn on any equipment when there is evidence of fire, water, or structural damage.
- ⑤ Disconnect the attached power sources, network connections, telecommunications systems, and serial cables before you open the device covers, unless you are instructed otherwise in the installation and configuration procedures.
- ⑥ Connect and disconnect cables as described in the following table when you install, move, or open covers on this product or attached devices.

WARNING: The protective earthing terminal, color is green, with washers and screws where a screw is threaded into it shall be not less than twice the pitch of the screw thread, at least 4.0mm diameter; Star washers or Spring washers can be used.

WARNING: After power off and disconnect from the equipment, then disconnect the frame of the equipment to earth.

Warranty Policy

Warranty Conditions

Products supplied by Atop Technologies are covered in this warranty for sub-standard performance or defective workmanship. The warranty is not, however, extended to goods damaged in the following circumstances:

- (a) Excessive forces or impacts
- (b) War or an Act of God: wind storm, fire, flood, electric shock, earthquake
- (c) Use of unqualified power supply, connectors, or unauthorized parts/kits
- (d) Replacement with unauthorized parts

RMA and Shipping Costs Reimbursement

Customers shall always obtain an authorized "RMA" number from Atop before shipping the goods to be repaired to Atop. When in normal use, a sold product shall be replaced with a new one within 3 months after purchase. The shipping cost from the customer to Atop will be reimbursed by Atop. After 3 months and still within the warranty period, it is up to Atop whether to replace the unit with a new one; normally, as long as a product is under warranty, all parts and labor are free of charge to the customers. After the warranty period, the customer shall cover the cost for parts and labor. Three months after purchase, the shipping cost from the customer to Atop will not be reimbursed, but the shipping cost from Atop to the customer will be paid by Atop.

Limited Liability

Atop shall not be held responsible for any consequential losses from using Atop's product.

Warranty Period

Product Categories	Warranty	Product Categories	Warranty
Ethernet Switches	5 Years	DIN-Rail Power Supplies	3 Years
Wireless		Power Adaptors	1 Year
Serial Device Servers			
Modbus Gateways			
Media Converters			
Embedded Device Servers	Other Accessories		
PoE Injectors			
Remote I/O			

The warranty certification will not be effective until an authorized stamp issued by Atop's overseas agents.

Purchase Date: / / (yyyy/mm/dd)

Serial Number



Atop Customer Services and Supports

1. Please contact your local dealers or Atop Technical Support Center at the following numbers.
+ 886-3-550-8137 (Atop Taiwan)
+ 86-21-6495-6232 (Atop China)
2. Please report the defected problems via Atop's Web site or E-mail account
Web Site : www.atop.com.tw, e-mail : service@atop.com.tw
Web Site : www.atop.com.cn, e-mail : service@atop.com.cn

