



FEATURED HIGHLIGHTS

- IEC 61850-3 HV & IEEE 1613 Certified NTP Server & IEEE 1588 PTP Grandmaster
- -40 to +85°C Operating Temperature with Input Voltage of HVDC and HVAC
- Proven PRTC-B (<40ns), PTP (<40ns), and NTP (<80 μs) Accuracy, Tested by Calnex
- Excellent Holdover Performance: <0.5 μs/8 Hours
- Supports Multiple Constellations with Jamming and Spoofing Mitigation
- Antenna Vulnerability Mitigation: Short and Disconnection
- Supports Power, Telecom Profiles, AVBTSN and Media Broadcast Profiles
- Redundancy: Power, System (Clustering), Network (PRP), and Link (Bonding & Combo Ports)
- Configurable IRIG-B (TTL, AM and RS-485), PPS and 10MHz Wave Output
- Compensation for Antenna and Sync-Out Cable Delay
- 2 Combo Ports and Dedicated Management Ports (Ethernet and Console)

PRODUCT DESCRIPTION

IEC61850-3 HV & IEEE 1613 Certified NTP Server & IEEE 1588 PTP Grandmaster with -40 to +85°C Operating Temperature

Our state-of-the-art NTP Server and IEEE 1588 PTP Grandmaster NTS8600 is fully certified to IEC61850-3 HV & IEEE 1613 standards, ensuring robust performance and reliability in harsh substation environments. Designed to deliver precise time synchronization across your entire power grid infrastructure, this device offers superb accuracy and stability. The IEC61850-3 HV & IEEE 1613 certification guarantees that our NTP Server & PTP Grandmaster can withstand electromagnetic interference, temperature fluctuations, and other environmental stresses typical of substation settings, ensuring uninterrupted performance and enhanced system reliability.

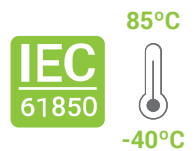

High Precision Timing

Rigorously tested by Calnex Solutions, a leader in network synchronization testing, the NTS8600 series delivers exceptional time precision, ensuring your power applications' synchronization needs are met with the highest standards of accuracy. Featuring proven PRTC-B accuracy within 40 ns, IEEE 1588 PTP accuracy within 40 ns, and NTP accuracy within 80 μs, this Grandmaster guarantees precise time distribution across your network.

Superior Holdover Performance

The performance of GMC holdover is important because it ensures continuous and accurate time synchronization during interruptions of primary time sources. The NTS8600 series delivers exceptional holdover performance, achieving less than 0.5 μs drift within 8 hours, as measured by Calnex Solutions. Additionally, when the system enters holdover mode, it will adjust the corresponding protocol attributes based on power profiles and proactively send notifications via alarms and syslog.





Versatile Profile Support and Upgradeability

Designed with exceptional versatility, our Grandmaster supports key power profiles such as IEEE C37.238-2011 & 2017 and IEC/IEEE 61850-9-3 2016. This ensures seamless integration into modern power substation environments, providing precise and reliable time synchronization. Additionally, the Grandmaster is fully upgradeable to telecom standards with SyncE support and TSN profiles such as ITU-T G.8265.1 Frequency, 8275.1 Phase/Time, 8275.2 Phase/Time, and 802.1AS, offering future-proof flexibility for expanding your network's applications.

GNSS Vulnerability Mitigation and Antenna Protection

NTS8600 offers enhanced robustness and resilience against jamming and spoofing attacks. By receiving signals from multiple constellations for verification, the system can provide spoofing detection and enter holdover mode if necessary. The Grandmaster also features comprehensive antenna vulnerability mitigation, detecting shorted and disconnected antennas to maintain system integrity. For added protection, a surge protector is available for purchase, safeguarding your equipment from electrical surges and ensuring the reliability of your timing infrastructure.

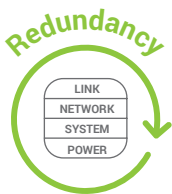

Comprehensive Redundancy

System redundancy is guaranteed by clustering featuring IEC 62439-3 Parallel Redundancy Protocol (PRP) to ensure network redundancy without data loss or downtime. Link redundancy is achieved through bonding, providing resilient connectivity. Additionally, NTS8600 series offers power redundancy options, including dual DC inputs or a combination of one DC and an external HVAC/HVDC power supply, to safeguard against power failures.

Flexible Timing Output

Modulated IRIG-B is ideal for long-distance transmission due to its resistance to signal degradation and compatibility with legacy equipment. Demodulated IRIG-B, available in TTL or RS-485 formats, offers higher precision, with IRIG-B RS-485 supporting distances up to 1200 meters. PPS and 10MHz outputs are crucial timing signals in modern IEC 61850 power applications, providing precise synchronization essential for various grid operations. The NTS8600 series features up to six configurable outputs, including IRIG-B TTL, AM, RS-485, 1-PPS, and 10MHz waveform. Additionally, IRIG-B RS-485 can be extended over long distances using the ATOP SF63 serial-to-fiber converter via fiber-optic cable.

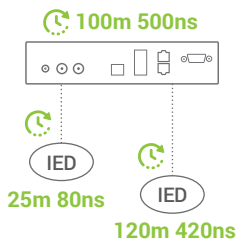
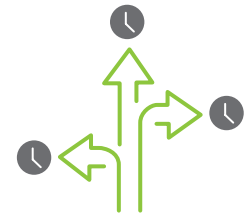

Ensuring Precision with Comprehensive Delay Compensation

Compensation for antenna delay is essential because long antenna cables can introduce timing errors that affect the accuracy of synchronized operations. Similarly, output delay compensation for signals such as IRIG-B and PPS is vital, especially in systems with multiple IEDs connected. It is much easier and more efficient to compensate for cable delays at the Grandmaster level rather than at each individual IED, as not all IEDs support delay compensation. Handling these adjustments centrally at the Grandmaster guarantees that all connected devices operate in perfect sync, optimizing the performance and coordination of critical substation operations.

APPLICATION CASE

IEEE 1588 in Power Networks: Precision Time Synchronization and Time Redundancy

Two NTS8600 units in the station layer determine the Active and Backup GMC through BMCA. The Active GMC synchronizes to both GPS and GNSS satellite systems and transmits via IEC 62439-3 PRP to two power domains composed of PRP and HSR networks. According to IEC 61850-9-3 and IEEE C37.238-2017, the total end-to-end budget is 1us, with GMC being 250ns. The NTS8600 achieves superior accuracy of <40ns, reserving more budget for other devices. For early MU devices that rely on 1PPS or IRIG-B for synchronization, the NTS8600 offers 1PPS, IRIG-TTL, IRIG-B AM, IRIG-B RS-485, and RS-485 to fiber-optics by SF-63 for long-distance transmission and delay compensation.

The HSR network provides zero-packet-loss redundancy but also increases latency. Devices in the process layer require more precise timing. When the end-to-end budget cannot be met, a GMC must be deployed to aid in accurate timing for critical devices. The NTS8600, certified to IEC61850-3 HV & IEEE 1613, operates reliably in harsh process layer environments, providing precise synchronization.

In addition to the NTS8600, our timing solution for power substations also includes BC or TC of RHG9728 and RHG9528, P-Delay TC of EH9711, HSR Redbox, and Quadbox of RGB700X. Check our website for more detailed information on these products

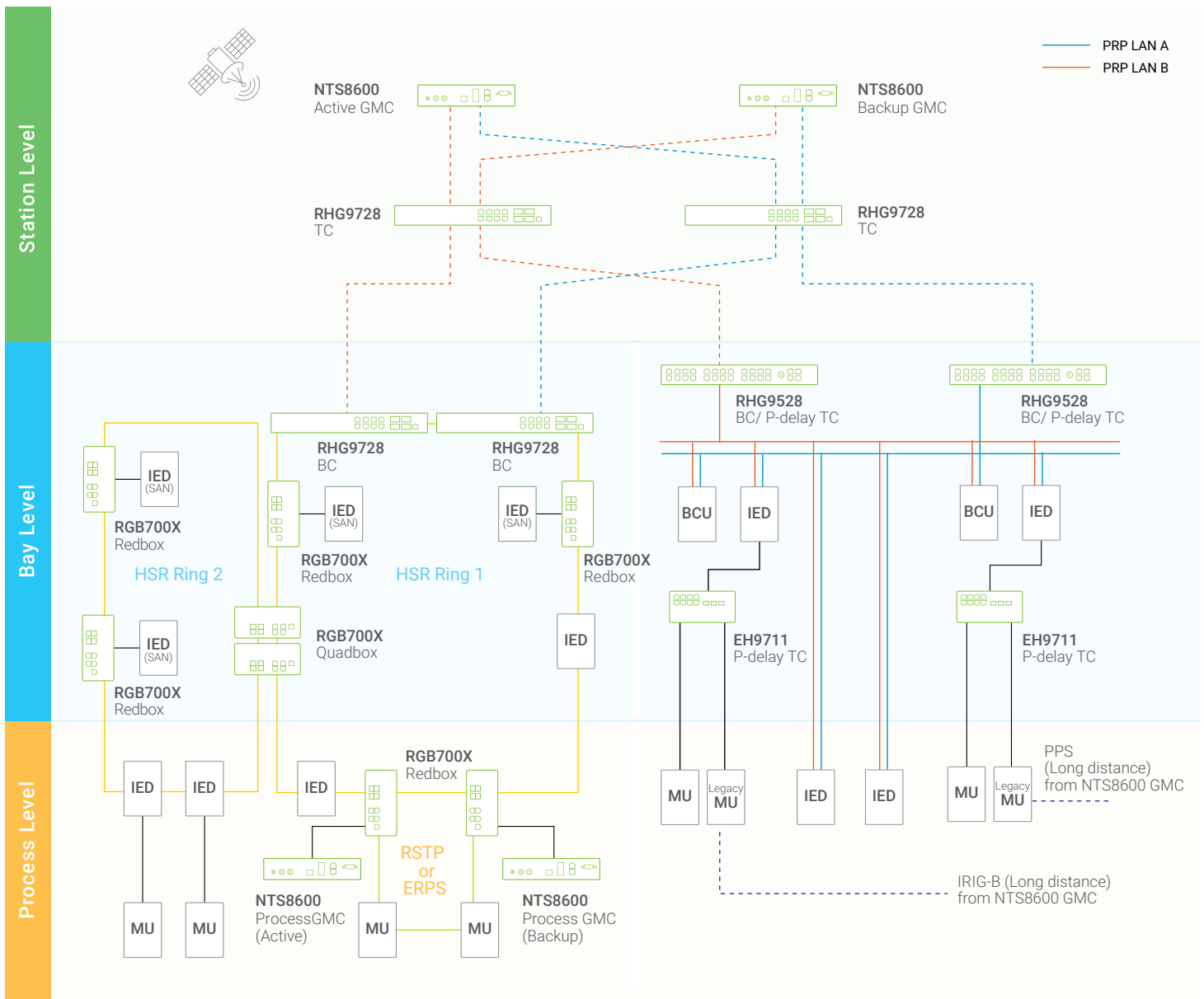

CONNECTORS

Front View

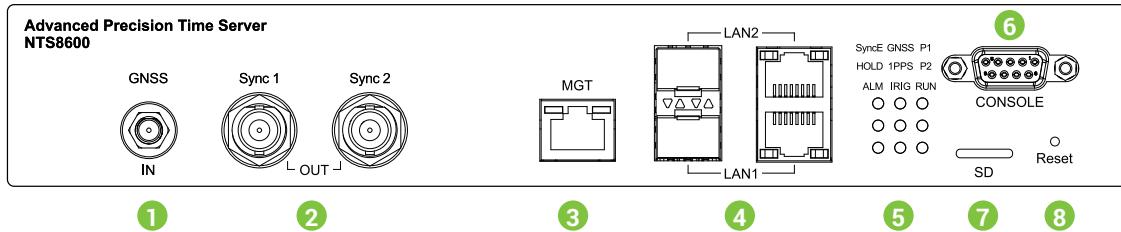

Back View

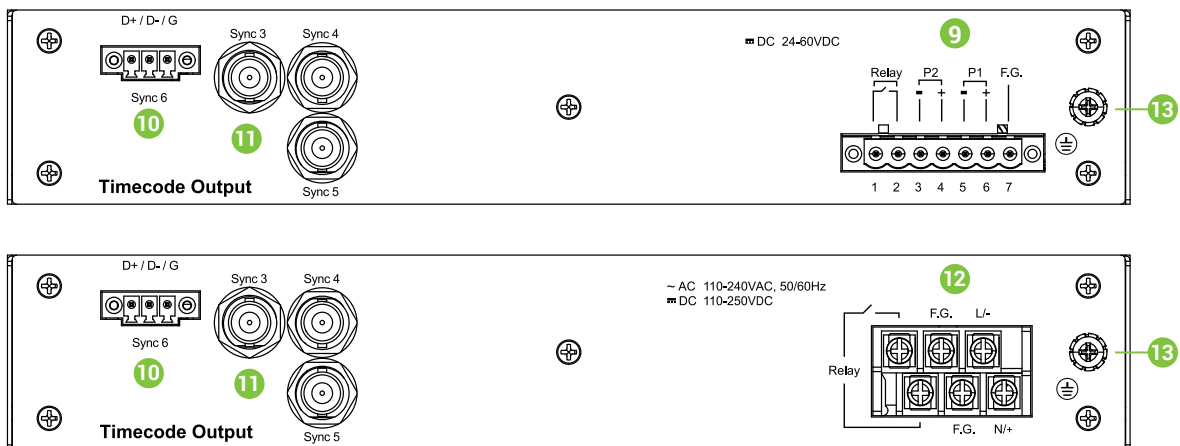

- 1 GNSS Antenna Input (SMA)
- 2 Synchronized Time Output 1~2 (BNC)
- 3 Management Ethernet Port
- 4 LAN / SFP Combo Port
- 5 Status Indicator (LEDs)
 - SyncE: SyncE Status
 - HOLD: Holdover Status
 - ALM: System Warning Alert
 - GNSS: Satellites Status
 - 1PPS: Pulse-Per-Second Status
 - IRIG: IRIG-B Timecode Output Status
 - P1: Power 1 Connection Status
 - P2: Power 2 Connection Status
 - Run: System Working Status
- 6 Console Port (DB9)
- 7 MicroSD Card Slot
- 8 Reset Button (Default)
- 9 DC Power Input / Relay Output (TB7)
- 10 Synchronized Time Output 6 (TB3)
- 11 Synchronized Time Output 3~5 (BNC)
- 12 AC Power Input / Relay Output (M3 Screw)
- 13 Protected Earth (M4 Screw)

DIMENSIONS & LAYOUT

Front View

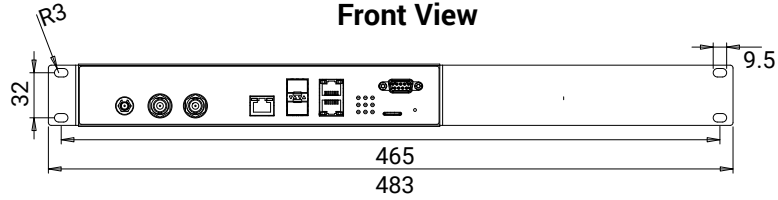

Side View

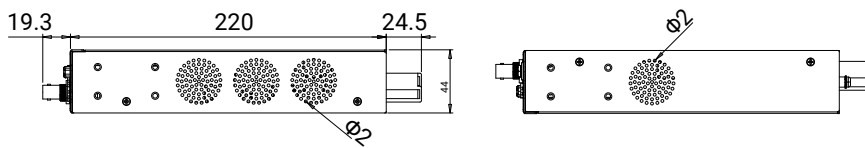

Back View

NTS8600-AC

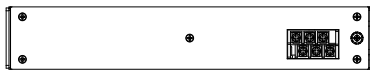

NTS8600-DC

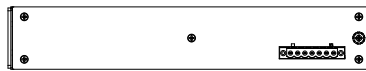

NTS8600I-AC

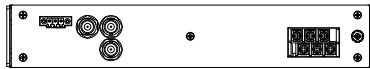

NTS8600I-DC

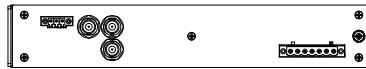

Top View

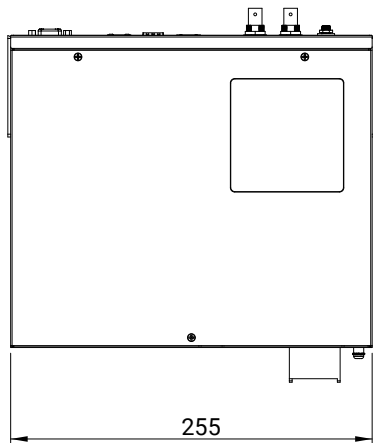

Rackmount Installation View

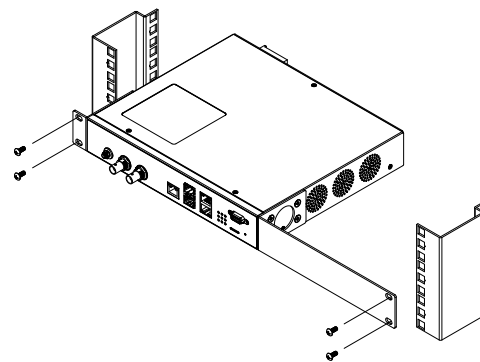

unit: mm

SPECIFICATIONS

Technical Specifications		
Model Name	NTS8600/NTS8600I Series	
GNSS Receiver Specifications		
GNSS Input ports	1x GNSS Input; SMA (F) - active Antenna	
GNSS Module specific Information	Multi-Constellation Supported: GPS L1, GLONASS L1, BeiDou B1, Galileo E1 GNSS Module latency: <15ns GNSS/1PPS output latency Leap Second: Supported GNSS constellations: Supported	
Acquisition Times	Cold Start: < 45 seconds Warm Start: < 7 seconds	
Antenna Requirements	3.3 V, < 50 mA Minimum gain=5dB; Maximum gain = 40dB	
GNSS Vulnerability Mitigation	Jamming	Support Detection, Warning and Switch to OCXO Holdover
	Spoofing	Support Detection, Warning and Switch to OCXO Holdover (GNSS Antenna Only)
Antenna Vulnerability Mitigation	Antenna Cable Short	Support Detection, Warning and Switch to OCXO Holdover Mode
	Antenna Disconnection	Support Detection, Warning and Switch to OCXO Holdover Mode
Antenna specification (Accessories)		
GNSS Antenna (59902521G)	GNSS receiver: GPS L1, GLONASS L1, BeiDou B1, Galileo E1 LNA Gain: 40dB min Weather-Proof Housing: IP69K Operating and Storage Temperature: -40°C ~85°C ESD: ±15KV Air Discharge Mechanical size: 66.5 mm dia. x 21 mm H MIL-STD-810F Supply Voltage Range: 2.5 to 16VDC	
GPS Antenna (59902531G)	GNSS receiver: GPS L1, Galileo E1 LNA Gain: 40dB min Weather-Proof Housing: IP69K Operating and Storage Temperature: -40°C ~85°C ESD: ±15KV Air Discharge Mechanical size: 66.5 mm dia. x 21 mm H MIL-STD-810F Supply Voltage Range: 2.5 to 16VDC	
Maximum Antenna Cable Length	Antenna cable: Without amplifier: LMR-400: 150M RG58A/U: 25M With Amplifier: LMR-400: 300M RG58A/U: 50M	
Maximum Sync-Out Cable Length	RG58 A/U Sync-Out cable: 1PPS, 10MHz, IRIG-B TTL: 150M IRIG-B AM: 150M @ 1K impedance , 300M @ 10K impedance IRIG-B RS485: 1200M IRIG-B RS-485 with SF63 Fiber optic 2KM	

Proven Clock Accuracy (Relative to UTC)	
1PPS	±40 ns Peak *1
Demodulated IRIG-B	±40 ns Peak *1
Modulated IRIG-B AM	±1 µs Peak *1
RS-485 IRIG-B	±100 ns Peak *1
PTP Timestamp	±40 ns Peak *1
NTP Timestamp	±80 us Peak , ±40 us Average *1
Holdover accuracy - OCXO	< 0.5 us / 8 hours *2
*1. Device locked to satellites for at least 24 hours. *2. Device locked to satellites for at least 48 hours before holdover	
Network Interface	
Ethernet Standards	IEEE 802.3 10BaseT IEEE 802.3u 100BaseT(X) IEEE 802.3ab for 1000BaseT(X) IEEE 802.3u for 100Base-FX IEEE 802.3z for 1000Base-X
PTP Ports	Two Combo ports, 2x 10/100/1000BASE-T(X) RJ45 or 2x 100/1000 Base-X SFP Support Synchronous Ethernet (SyncE)
Management Port	1x 10/100 BASE-T(X) RJ45
I/O	
Console	1x DB9 Serial Console Port
SD slot	1x micro-SD slot
Relay - Alarm Contact	Rated Operational Voltage: 24 VDC Continuous carrier: 1A Normal Open Pickup time: 2.5ms Turn-off time: 1ms
Sync-Out	
Standard Sync-Out (Sync 1, Sync 2)	Two configurable output channels (coaxial BNC (F) connector): 1. 10 MHZ 2. 1PPS Output (Square Wave, 500ms pulse width) 3. IRIG-B TTL (Support IEEE1344 and C37.118.1) 4. AFNOR French Time Code 5. BCD, BJT, ST and ST Checksum (Contact sales for these timecodes)
Extend Sync-Out (NTS8600I) (Sync 3 ~ Sync 6)	Three extra configurable output channels (Sync 3 ~ Sync 5, coaxial BNC (F) connector): 1. 10 MHZ 2. 1PPS Output 3. IRIG-B TTL B000~B007 (Support IEEE1344 and C37.118.1) 4. IRIG-B AM B120~B127 (Support IEEE1344 and C37.118.1) 5. AFNOR French Time Code 6. BCD, BJT, ST and ST Checksum (Contact sales for these timecodes) One extra standalone channel (Sync 6, TB3 connector) 1. IRIG-B RS-485 B000~B007 (Support IEEE1344 and C37.118.1)
Electrical Output Drive Levels	
1PPS & 10 MHZ	Sync 1 & 2: 5VDC TTL compliant / 2.4VDC @ 50 Ohm impedance Sync 3 ~ 5: 5VDC TTL compliant
IRIG-B TTL	5 VDC TTL compliant
Modulated IRIG-B	5Vp-p, 3:1 ratio, AM, Sinewave
IRIG-B RS485	±5VDC

Frequency		
Oscillator	Advanced managed OCXO, with temperature drifting compensation	
IEEE1588 Profiles		
Default	IEEE 1588V2 (PTPv2) Default UDP (IEEE1588-2008 Annex D and J) Default 802.3 (IEEE1588-2008 Annex F and J)	
Power	IEC/IEEE61850-9-3-2016 Power Utility Profile IEEE C37.238-2011 Power Profile, with VLAN support IEEE C37.238-2017 Power Profile, with VLAN support	
*Telecom (In Development Plan)	ITU-T G.8265.1 Frequency ITU-T G.8275.1 Phase/Time ITU-T G.8275.2 Phase/Time Telecom-2008	
*AVBTSN (In Development Plan)	802.1AS profile	
*Media Broadcast (In Development Plan)	SMPTE ST 2059-2 AES67 Media Profile	
System Modes		
GNSS Locked Mode	Synchronizes time with GNSS signals for high accuracy	
Holdover Mode	Maintains time using the OCXO clock after GNSS is unavailable	
Free Run Mode	Operates independently using RTC as the time source along with the OCXO clock.	
Functions & Protocols		
Protocols	Network Synchronization	RFC 1119 (NTPv2) Server RFC 1305 (NTPv3) Server RFC 5905 (NTPv4) Server RFC 1769 (SNTPv3) Server RFC 2030 (SNTPv4) Server
	Network Protocols	VLAN (IEEE 802.1q) filtering/tagging IEEE 802.1p QoS DSCP IPv4, IPv6 TCP, UDP DHCP Client TACAS+/ RADIUS
	Redundancy	Devices Clustering (NTP Only) PRP (IEC 62439-3) Bonding – Active & Backup Bonding – LACP Combo Ports
	Management	HTTP, HTTPS SNMP v1/v2,v3 SSH/ Telnet (CLI), could be enabled/disabled Console CLI Estimated Time Accuracy GNSS Status Power Status PTP & NTP Status SD/MMC Backup & Restore
	Event & Alarm	Event Log Syslog Relay & Alarm Management SNMP Trap

Physical Characteristics	
Housing Dimension (W x H x D) Weight Installation	SPCC IP30 Metal Housing 252.8 x 220 x 44 2KG (AC + IRIG-B) / 1,9KG (DC + IRIG-B) 1U Rack-mountable
Power Supply	
Rated Supply Voltage	110 – 240 VAC, 0.2-0.3A, 50/60HZ (AC series) 110 – 250 VDC, 0.06-0.15A (AC series) 24 – 60 VDC, 0.24-0.6A (DC series)
Input Voltage Range	85 – 264 VAC, 0.2-0.35A, 50/60 HZ (AC series) 88 – 300 VDC, 0.06-0.15A (AC series) 19 – 66 VDC, 0.2-0.8A (DC series)
Environmental Limits	
Operating Temperature Storage Temperature Ambient Relative Humidity	-40°C to +85°C (-40°F to 185°F) -40°C to +85°C (-40°F to 185°F) 5% to 95% (Non-condensing)

REGULATORY APPROVALS

Regulatory Approvals				
Safety	UL 62368-1 , CB IEC62368-1/EN62368-1 (UL Certified Operating Temperature: 75°C)			
EMC	FCC(EMI): FCC Part 15, Subpart B, Class A CE(EMI): EN 55032, EN61000-6-4, Class A EN 61000-3-2 (Current Harmonics) EN 61000-3-3 (Voltage Flicker) CE(EMS): EN 55035, EN61000-6-2 CE(GNSS): EN 303 413. EN 301 489-19			
Power Automation	IEC61850-3, IEEE 1613			
Test	Item	Value	Level	
IEC 61000-4-2	ESD	Contact Discharge	±8KV	4
		Air Discharge	±15KV	4
IEC 61000-4-3	RS	Enclosure Port	10(V/m), 80-3000MHz 20(V/m), 80-1000MHz	3
IEC 61000-4-4	EFT	AC Power Port	±4.0KV	4
		DC Power Port	±4.0KV	4
		Signal Port	±2.0KV	Special
IEC 61000-4-5	Surge	AC Power Port	Line-to Line±2.0kV	4
		AC Power Port	Line-to Earth±4.0kV	4
		DC Power Port	Line-to Line±1.0kV	4
		DC Power Port	Line-to Earth±2.0kV	4
IEC 61000-4-6	CS	0.15-80MHz	10V rms 0.15-80MHz, 80% AM	3
		PFMF	(Enclosure)	100A/m continuous, 1000A/m (3s)

IEC 61000-4-11	DIP	AC Power Port	30% reduction (Voltage Dips), 1 period 60% reduction (Voltage Dips), 50 period 100%, reduction (Voltage interruptions), 5 period 100% reduction (Voltage interruptions), 50 period	-
IEC 61000-4-16	Main Frequency Voltage	DC Input Port Signal Port	30V Continuous, 300V 1s 30V Continuous, 300V 1s	4 4
IEC 61000-4-17	Ripple	DC Input Port	10% of unit	3
IEC 61000-4-18	Damped Oscillatory	AC Power Port	2.5KV common, 1KV differential mode @ 1MHz	3
		Signal Port Telecom- munication Port	2.5KV common, 1KV differential mode @ 1MHz	3
IEC 61000-4-29	DC Voltage Dips & Interruptions	DC Input Port	30% Reduction (Voltage Dips):0.1 sec 60% Reduction (Voltage Dips):0.1 sec 100% Reduction (Voltage Interruption):0.05 sec	
Shock Drop Vibration	MIL-STD-810G Method 516.5 MIL-STD-810F Method 516.5 MIL-STD-810F Method 514.5 C-1 & C-2			
RoHS2	Yes			
MTBF	20 years			
Warranty	5 years			

ORDERING INFORMATION

Main core and Modules

Model Name	Part Number	Ethernet Port	Sync-Out	Input Voltage Range
NTS8600-DC	1P1NTS86000001G	1 x 10/100 MGMT RJ45 port and 2 x 10/100/1000 RJ45/SFP combo ports	Standard Sync-Out (Total Sync-Out Channels: 2)	Dual 19-66 VDC
NTS8600-AC	1P1NTS86000002G			Single 85-264 VAC or 88-300 VDC
NTS8600I-DC	1P1NTS8600I001G		Extend Sync-Out (Total Sync-Out Channels: 6)	Dual 19-66 VDC
NTS8600I-AC	1P1NTS8600I002G			Single 85-264 VAC or 88-300 VDC

* Dual AC can be achieved by using two external power supplies or by choosing the NTS8610

Optional Accessories

Model name	Part Number	Description
SDR-75-24	50500752240001G	DIN RAIL POWER SUPPLY / T; 88~264VAC/ 124~370VDC to 24VDC 3.2A; 75W
SF63 Series	See ATOP SF63 Data-sheet	Industrial Serial to Fiber Media Converter for long distance transmission

GNSS Antenna Package	70100000000090G	This package includes 1. High Gain Multi-Constellation TNC-Female Antenna (GPS L1, GLONASS L1, BeiDou B1, Galileo E1) 2. 2 meters SMA Male to TNC Male antenna cable
GPS Antenna Package	70100000000091G	This package includes 1. High Gain GPS L1 TNC-Female Antenna 2. 2 meters SMA Male to TNC Male antenna cable
RF Amplifier	70100000000092G	Inline TNC-Female RF (1559-1610MHz) Amplifier 25dB with supply volts 3-10 VDC and 10mA
Surge Protector	70100000000093G	SOCAA 4LTJ10TP001 – TNC-Female 10KA Surge protection device
Advanced Surge Protector	70100000000094G	Phoenix Contact CN-UB-280DC-BB – N-Type 20 KA Surge protection device including two N-type Male to TNC Female adapters
Mounting Kits	70100000000095G	The antenna mounting kit includes an L-bracket, mount adapter and ground plane. (See NTS8600 Accessories Guide for more details)
AXFD-1314-0523	522AXFD1314001G	SFP Transceiver, 155Mbps, 1310nm, Multi-mode, 2km, -40°C to +85°C, DDMI
AXFD-1314-0553	522AXFD1314011G	SFP Transceiver, 155Mbps, 1310nm, Single-mode, 30km, -40°C to +85°C, DDMI
AXGD-5854-0513	522AXGD5854001G	SFP Transceiver, 1250Mbps, 850nm, Multi-mode, 550m, 3.3V, -40°C to +85°C, DDMI
AXGD-1354-0523	522AXGD1354001G	SFP Transceiver, 1250Mbps, 1310nm, Multi-mode, 2km, 3.3V, -40°C to +85°C, DDMI
AXGD-1354-0533	522AXGD1354011G	SFP Transceiver, 1250Mbps, 1310nm, Single-mode, 10km, 3.3V, -40°C to +85°C, DDMI
AXGD-3354-0593	522AXGD3354001G	SFP Transceiver, 1250Mbps, 1310nm, Single-mode, 40km, 3.3V, -40°C to +85°C, DDMI