



**ATOP Technologies, Inc.**

**Advanced SyncPro: IEC 61850-3 Certified NTP Server & IEEE 1588 PTP Grandmaster**

**NTS8600**

## Hardware Installation Guide

Version 1.1  
Updated in Feb. 2025



## Package Check List

Inside the package you will find the following items:

- Grandmaster PTP & NTP Server x1
- Rack mount kit x 1
- Countersunk Flat Head Screws x 8
- NTS8600I Series Only: RS-485 Terminal block 3.81pitch x 1 (TB3)
- SMA Male to TNC Female connector x 1
- DC Power Version Only: Terminal Block 5.08mm pitch. x 1 (TB7)
- Protective caps for all SFP ports
- Installation Guide with Warranty Card x 1

- ⚠ Never install or work on electrical or cabling during periods of lightning activity. Never connect or disconnect power when hazardous gases are present.
- ⚠ Warning: Hot Surface Do Not Touch.
- ⚠ Caution: CLASS 1 LASER PRODUCT. Do not stare into the laser!
- 🏠 This equipment should be installed indoor and not connect directly with equipment installed outdoor.
- ♻️ Throw the device must follow RoHS procedure to recycle

## Product Layout

### Front View

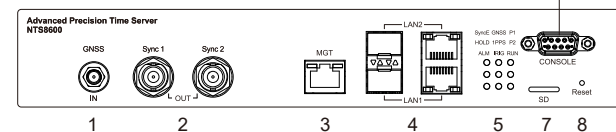

### Back View

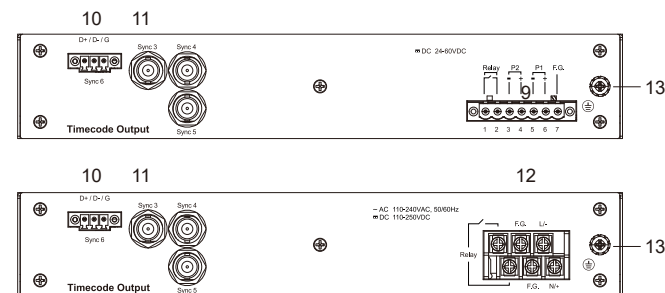

- |                                       |  |
|---------------------------------------|--|
| 1. GNSS Antenna Input (SMA)           | 6. Console Port (DB9)                        |
| 2. Synchronized Time Output 1-2 (BNC) | 7. MicroSD Card Slot                         |
| 3. Management Ethernet Port           | 8. Reset Button (Default)                    |
| 4. LAN / SFP Combo Port               | 9. DC Power Input / Relay Output (TB7)       |
| 5. Status Indicator (LEDs)            | 10. Synchronized Time Output 6 (TB3)         |
| - SyncE: SyncE Status                 | 11. Synchronized Time Output 3-5 (BNC)       |
| - HOLD: Holdover Status               | 12. AC Power Input / Relay Output (M3 Screw) |
| - ALM: System Warning Alert           | 13. Protected Earth (M4 Screw)               |
| - GNSS: Satellites Status             |  |
| - 1PPS: Pulse-Per-Second Status       |  |
| - IRIG: IRIG-B Timecode Output Status |  |
| - P1: Power 1 Connection Status       |  |
| - P2: Power 2 Connection Status       |  |
| - Run: System Working Status          |  |

## Installation Overview

The device's appearance is as in the figure below.

### 1. Safety Precautions

- First, thoroughly read the precautions in the antenna installation manual.
- Ensuring the safety of personnel during antenna installation is paramount; proper safety measures must be taken.

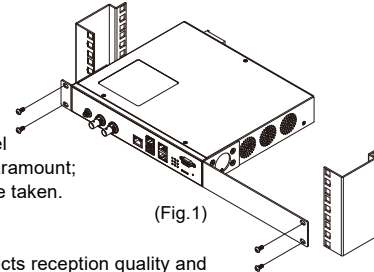

### 2. Antenna Installation

- The location of the antenna affects reception quality and the equipment's susceptibility to interference and damage.
- Choose a wide, open area with an unobstructed view of the sky, free from nearby obstructions such as buildings, trees, and walls (refer to the Antenna Installation Guide in user manual for more details).

### 3. Rack Mounting

- If mounting the device on a rack, use the fixed rack kit.
- Attach the L-bracket to the device using M5 Phillips machine screws, then securely place it on the rack.
- The kit supports installation on either side.
- Rack Mount Screw Specifications: M4 screw depth: 6.0 mm (Max); 8 screws required.

### 4. Grounding and Cable Management

- Properly ground the device using the FG pin in the wiring box. Always connect to the ground for optimal performance.
- The front panel GNSS SMA input port has a female connector; ensure the cable connector matches properly. Manage the cable's diameter and weight to avoid damaging the SMA port.

### 5. Power On

- After completing all previous installation steps, power on the device by connecting it to a reliable power source.
- Ensure grounding is properly established before powering on to maintain safety and optimal performance.
- Refer to the user manual for specific power requirements if needed.

### 6. GNSS Antenna and Cable Selection

- The GNSS active antenna is essential for this device. Choose an appropriate active antenna and cable model according to the specifications in the user manual.
- The device supports GPS, GLONASS, Galileo, and Beidou systems.
- An additional GNSS SMA cable adapter is available to integrate with your antenna cable system, providing options and accessories for specific environments, such as lightning arresters, antenna amplifiers, and mounting brackets.
- Select components based on actual needs and securely connect the antenna and cable (refer to the Antenna Installation Guide in user manual).

### 7. Network Configuration

- The default factory IP settings for this time server are LAN1: 10.0.50.1 / LAN2: 192.168.1.1. / MGT: 192.168.2.1

- After connecting to the physical network, you can access the device through its Web UI (or use the management utility; for more information on the management utility, please refer to its manual).
- Note that the computer required for this process needs to be set within the same subnet, or you can refer to the device's user manual. The default factory information (username: admin / password: default).

## LED Indicators

LED	Color	State	Description
P1/ P2	Green	ON	PWR is connected
		OFF	PWR is disconnected
RUN	Green	Blinking	The System is running and ready
		OFF	The system is still booting up and is not yet ready.
GNSS	Green	ON	The GNSS is connected, and satellite lock has been established
		Blinking	The GNSS signal is present but has not met the user-defined lock conditions. (See GNSS Settings in the user manual)
		OFF	The antenna is disconnected, or the NTS8600 is operating in FreeRun mode
1PPS	Green	Blinking	PPS is transmitting
		OFF	No PPS transmission
IRIG	Green	Blinking	IRIG-B is transmitting
		OFF	No IRIG-B transmission
SyncE	Green	ON	SyncE Master is operating
		OFF	SyncE Master isn't operating
HOLD	Green	ON	Clock for Holdover mode is ready
		Blinking	System enters Holdover mode
		OFF	Clock for Holdover mode isn't ready
ALM	Red	ON	When an alarm occurs, the LED will stay on or blink as per the settings. (See Alarm Settings in the user manual)
		Blinking	
		OFF	No alarms have occurred among the configured alarms

LED	Color	State	Description
LAN1 & LAN2 Activity	Green	Blinking	Data transmission
		OFF	No data transmission
LAN1 & LAN 2 Link	Yellow	ON	Lan or SFP port is connected at 1000/100 Mbps
		OFF	Lan or SFP port is disconnected or Lan or SFP port is connected at 10 Mbps
MGT LAN Activity	Green	Blinking	Data transmission
		ON	No data transmission
MGT LAN Link	Yellow	ON	MGT port is connected at 100 Mbps
		OFF	MGT port is disconnected or MGT port is connected at 10 Mbps

## Environmental Limits

- Operating Temperature : -40°C ~85°C
  - UL certification: -40°C ~75°C
- Storage Temperature: -40°C ~85°C
- Ambient Relative Humidity: 5 to 95%RH (non-condensing)

## Field Maintenance and Service

If the device requires servicing of any kind, you may need to disconnect and remove it from its mounting. The initial installation should be done in a way that makes this as convenient as possible.

- Voltage/Power lines should be properly insulated as well as other cables. Be careful when handling the so as to not trip over
- Do not under any circumstance insert foreign objects of any kind into the heat dissipation holes located in the different faces of the device. This may not only harm the internal layout but might cause harm to you as well.
- Do not under any circumstance open the device for any reason. Please contact your dealer for any repair needed or follow the instructions on section of your User's Manual.

## Pin Assignments and Connections

100Base-FX and 1000Base-X Fiber Optics SFP Slot

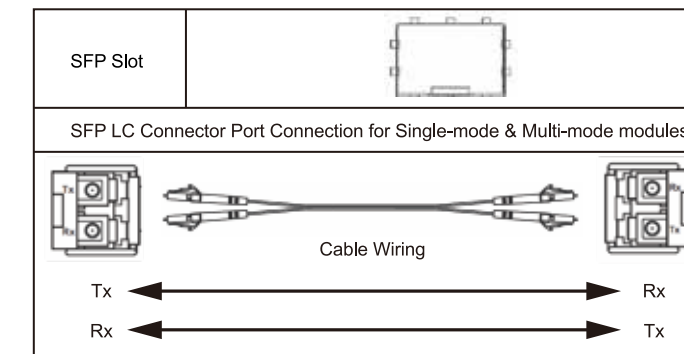

**Caution**  
The SFP slot should be used in conjunction with a MSA compliant optical transceiver.

GNSS SMA ANT Input	
TYPE	SMA(F), GNSS Active, Antenna Input
Specificity Requirement	3.3VDC, +/-5% , 50mA Max.

Output	Sync1	Sync2	Sync3*	Sync4*	Sync5*	Sync6
TYPE	BNC(F)	BNC(F)	BNC(F)	BNC(F)	BNC(F)	Terminal Block(TB3)
Mode	TTL 5V	TTL 5V	AM 5Vpp	AM 5Vpp	AM 5Vpp	RS-485
	50 OHM	50 OHM	TTL 5V	TTL 5V	TTL 5V	+/-5V
Function	IRIG-B DCLS/IRIG-B AM/1PPS/10MHZ					

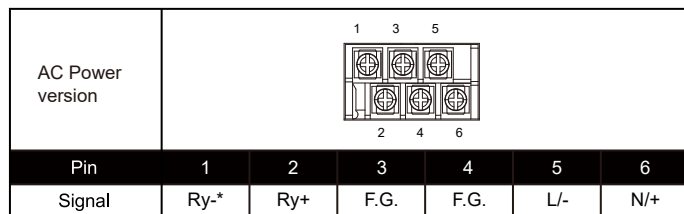
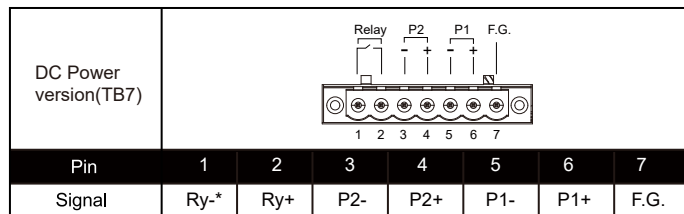

\*Ry-,Ry+ defined as Relay contact touch pin.

CONSOLE DB9(F)					
Pin	1	2	3	4	5
Signal	X	TX	RX	X	GND
Pin	6	7	8	9	
Signal	X	X	X	X	

## Power Requirements

- AC Version **NTS8600(I)-AC**  
Input Voltage: 85 ~ 264VAC, 0.2-0.35A, 50/60Hz  
88-300VDC, 0.06-0.15A  
Rated Voltage: 110 ~ 240VAC, 0.2-0.3A, 50/60Hz  
110-250VDC, 0.06-0.15A
- DC Version **NTS8600(I)-DC**  
Input Voltage: 19-66VDC, 0.2-0.8A  
Rated Voltage: 24-60VDC, 0.24-0.6A

Power Consumption: Approx. 9.4 W @ 264VAC (max)

## Attention

- Never open the equipment. For safety reasons, the equipment should be opened only by qualified skilled person.
- Equipment is intended for installation in Restricted Access Area.
- The DC supply source for the equipment power supplied shall be an UL certified power source and suitable for specification, rated 24-60Vdc, 0.8A minimum, Tma 75 degree C minimum or 110-250Vdc, 0.2A minimum provided by the manufacturer.
- The power cable connection wire type: copper, clamping torque:4.5 Lb-In(0.6 Nm). Please use the jacked power cable with 20 AWG minimum to connect between the equipment and power source.

- Earth terminal shall be used 20 AWG minimum size with green-and-yellow conductor to be connected to earth.
- CAUTION:  
Double pole, neutral fusing. Disconnect mains before serving. This equipment should be installed indoor by Skill person and do not connect directly with equipment installed outdoor.

### Installation manual of field wiring for Advanced SyncPro: IEC 61850-3 Certified NTP Server & IEEE 1613 PTP Grandmaster Power connected :

This equipment must be installed and removed by trained skilled person in a restricted-access location, as defined by the NEC and IEC 62368-1, The Standard for Safety of Audio/video, information and communication technology equipment.

### Safety statement

- CAUTION:



To reduce the risk of electric shock or energy hazards:

It is the customer's responsibility to supply the necessary power cable.

- Use a circuit breaker that is rated at 20 amps.
  - Use 0.75 mm<sup>2</sup> (18 AWG) single copper wire, or 1.5 mm<sup>2</sup> (14 AWG) Multi-core copper at 90° C.
  - Stripping the wire, leave the bare lead approximately 10mm for terminals connection.
  - Torque the wiring-terminal screws to 0.50 ~ 0.60 newton-meters (4.43 ~ 7 inch-pounds).
- If the power source requires ring terminals, you must use a crimping tool to install the ring terminals to the power cord wires. The ring terminals must be UL approved and must accommodate the wire that is described in above.
  - Power installation must be performed with qualified electrician and followed with National Electrical Code, "ANSI/NFPA 70 and Canadian Electrical Code, Part I, CSA C22.1."

This equipment is designed to permit the connection of the earthed conductor of the power supply circuit to the earthed conductor at the equipment.

This equipment is designed to permit the connection of the earthed conductor of the power supply circuit to the earthed conductor at the equipment.

If this connection is made, all of the following conditions must be met:

- This equipment shall be connected directly to the power supply system earthed electrode conductor or to a bonding jumper from an earthing terminal bar or bus to which the power supply system earthed electrode conductor is connected.
- This equipment shall be located in the same immediate area (such as, adjacent cabinets) as any other equipment that has a connection between the earthed conductor of the same dc supply circuit and the earthed conductor, and also the point of earthed of the power system. The power system shall not be earthed elsewhere.
- The power supply source shall be located within the same premises as this equipment.
- Switching or disconnecting devices shall not be in the earthed circuit conductor between the dc source and the point of connection of the earthed electrode conductor.

### To Connected Power to Advanced SyncPro: IEC 61850-3 Certified NTP Server & IEEE 1613 PTP Grandmaster:

- Turn OFF all power sources and equipment that is to be attached to this product.
- Attach signal cables to the product.
- Attach power cords to the product.
  - For dc systems, ensure correct polarity of 24-60VDC or 110-250VDC dc connections, Earth ground should use a two-hole lug for safety.
  - For AC systems, ensure correct polarity of connections, Earth ground should use a two-hole lug for safety
- Attach signal cables to other devices.
- Connect power cords to their sources.
- Turn ON all the power sources.

### To Disconnected Power to Advanced SyncPro: IEC 61850-3 Certified NTP Server & IEEE 1613 PTP Grandmaster:

- Turn OFF all power sources and equipment that is to be attached to this product.
- Disconnect dc power sources at the breaker panel or by turning off the power source. Then, remove the power cables.
- Remove the signal cables from the connectors.
- Remove all cables from the devices.

### Caution, Shock hazard

Disconnect all power sources



Electrical current from power, telephone, and communication cables is hazardous.

To avoid a shock hazard:

- Do not connect or disconnect any cables or perform installation, maintenance, or reconfiguration of this product during an electrical storm.
- Connect to properly wired power sources any equipment that will be attached to this product.
- When possible, use one hand only to connect or disconnect signal cables.
- Never turn on any equipment when there is evidence of fire, water, or structural damage.
- Disconnect the attached power sources, network connections, telecommunications systems, and serial cables before you open the device covers, unless you are instructed otherwise in the installation and configuration procedures.
- Connect and disconnect cables as described in the following table when you install, move, or open covers on this product or attached devices.

**WARNING:** The protective earthing terminal, color is green, with washers and screws where a screw is threaded into it shall be not less than twice the pitch of the screw thread, at least 4.0mm diameter; Star washers or Spring washers can be used.

**WARNING:** After power off and disconnect from the equipment, then disconnect the frame of the equipment to earth.

## Mechanical Dimensions

### Front View

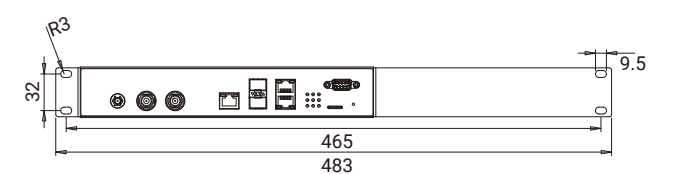

### Back View

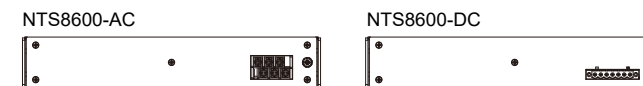

### Side View

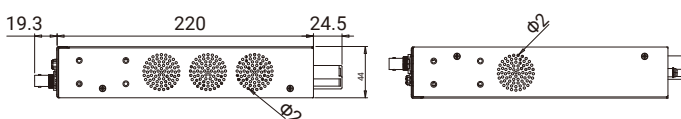

### Top View

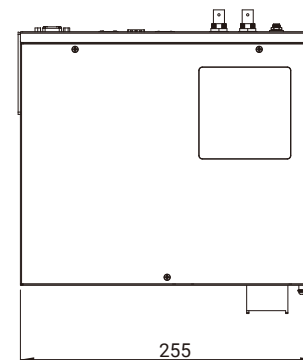

### Rackmount Installation View

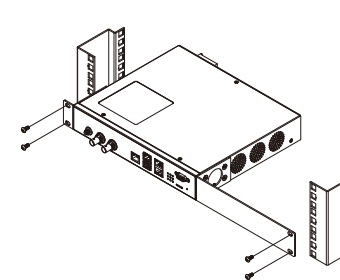

\*The Rack M5 screw are not included in the wall mount package

## Warranty Policy

### Warranty Conditions

Products supplied by ATOP Technologies are covered in this warranty for sub-standard performance or defective workmanship. The warranty is not, however, extended to goods damaged in the following circumstances:

- Excessive forces or impacts
- War or an Act of God: wind storm, fire, flood, electric shock, earthquake
- Use of unqualified power supply, connectors, or unauthorized parts/kits
- Replacement with unauthorized parts

### RMA and Shipping Costs Reimbursement

Customers shall always obtain an authorized "RMA" number from ATOP before shipping the goods to be repaired to ATOP. When in normal use, a sold product shall be replaced with a new one within 3 months after purchase. The shipping cost from the customer to ATOP will be reimbursed by ATOP.

After 3 months and still within the warranty period, it is up to ATOP whether to replace the unit with a new one; normally, as long as a product is under warranty, all parts and labor are free of charge to the customers.

After the warranty period, the customer shall cover the cost for parts and labor. Three months after purchase, the shipping cost from the customer to ATOP will not be reimbursed, but the shipping cost from ATOP to the customer will be paid by ATOP.

### Limited Liability

ATOP shall not be held responsible for any consequential losses from using ATOP's product.

### Warranty Period

Product Categories	Warranty	Product Categories	Warranty
Ethernet Switches /GM	5 Years	DIN-Rail Power Supplies	3 Years
Wireless		Antennas	
Serial Device Servers		Power Adaptors	1 Year
Modbus Gateways			
Media Converters			
Embedded Device Servers			
Grandmaster/ NTP Timeserver			

The warranty certification will not be effective until an authorized stamp issued by ATOP's overseas agents.

Purchase Date: / / (yyyy/mm/dd)

Serial Number

### ATOP Customer Services and Support

- Contact your local dealers or ATOP Technical Support Center at the following number: +886-3-550-8137
- Report any problems via ATOP's website or email  
[www.atoponline.com](http://www.atoponline.com)    [service@atop.com.tw](mailto:service@atop.com.tw)

